



# Ranger DQ500 T4 SURFACE DRILLS

## TECHNICAL SPECIFICATION

Ranger DQ500 is a hydraulic, self-propelled, self-contained, crawler based surface drilling rig equipped with a cabin (F.O.P.S. and R.O.P.S.) and rod handling system.

Ranger Ranger DQ500 is meant for pilot hole drilling in dimensional stone quarries.

### KEY FEATURES

Hole diameter:	45- 89 mm (1¾"- 3½")
Rock tools:	32, 38 or 45 mm (1¼", 1½", and 1¾") rods
Rock Drill	15,5kW
Engine output:	168 kW
Flushing air:	6,2 m3/min, up to 10 bar
Production capacity:	2000 m3/8h
Total weight :	15 400 kg



#### STANDARD COMPONENTS

1 pc Rock drill HL 510, hydraulic, w. OMSU200
1 pc Chain feed CF 145H x 12 with two ground supports and movable drill steel support
1 pc Rod handler RH 714 incl. 1 set of jaws
1 pc Hose reel
1 pc Boom DB 800 SW, articulated with roll-over
1 pc Carrier track mounted, turnable superstructure
1 pc Turnable superstructure 180 deg.
1 pc Power pack diesel driven, hydraulic pumps and on-board compressor
1 pc Hydraulic system load sensing and open center
1 pc Control system Rockpilot + Full radio control for drilling, boom, and rodhandling movements
1 pc Operator's cabin F.O.P.S. and R.O.P.S. with AC
1 pc Dust collection system DC 810 H, hydraulic
9 pcs Working lights
1 pc Gaugeset for accumulator checking
1 pc Backup alarm
1 Set Manuals, paper copy
1 Set Manuals, USB memory
EU-safety devices, EN16228

#### THE JAWS FOR DRILL STEELS

DRILL STEEL TYPE	DRILL STEEL DIAMETER	RECOMMENDED HOLE DIAMETER
Extension rods	32 mm 1 1/4"	45 - 57 mm 1 3/4" - 2 1/4"
MF-rods	32 mm 1 1/4"	45 - 57 mm 1 3/4" - 2 1/4"
Extension rods	38 mm 1 1/2"	64 - 70 mm 2 1/2" - 2 3/4"
MF-rods	38 mm 1 1/2"	64 - 70 mm 2 1/2" - 2 3/4"
Extension rods	45 mm 1 3/4"	76 - 89 mm 3" - 3 1/2"
MF-rods	45 mm 1 3/4"	76 - 89 mm 3" - 3 1/2"

#### SELECTION OF OPTIONS

Alternative seat ISRI 6000
Radio with CD-MP3 player
Reversing camera
Vacuum cleaner for cabin
TIM 5600 for vertical and horizontal holes and depth measuring
Kit for alternative steels, each
Thread greasing
Thread greasing with 5 gallon bucket
Anti- freeze system for air lines
Biogradeable hydraulic oil, not with CSL
Central lubrication system Sandvik
Electric fuel filling pump
Guides for grousers, long
Hydraulic rear ground support
Three bar grouser plates
Towing hook
Winch with radioreMOTE control and cable tightness automatics
Xenon lights, 6 pcs
Fuel powered heater for engine and cabin
Fuel powered heater for engine, cabin and water tank
Readyness for fuel powered heater
Dustmizer (engine heater option needed below freezing point)
Flushing control automatics
Shut down of suction for water holes
Water injection system
Extra manuals, price will be added according to pricing sheet
First service kit for DX500
Special tools for HL 510, field kit
Special tools for HL 510, complete
Service agreement - select level from extra item
SanRemo - select level from extra item

COVERAGE AREA AND DIMENSIONS

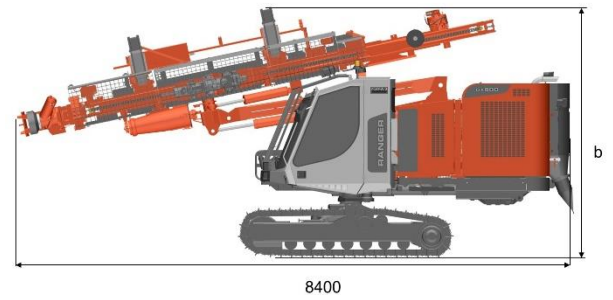
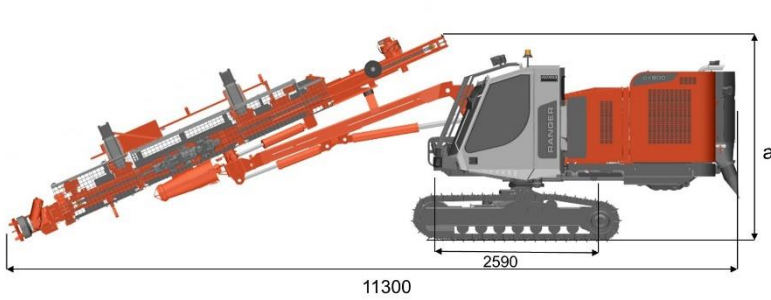
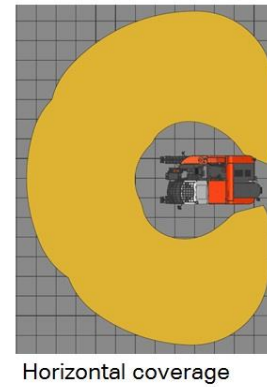
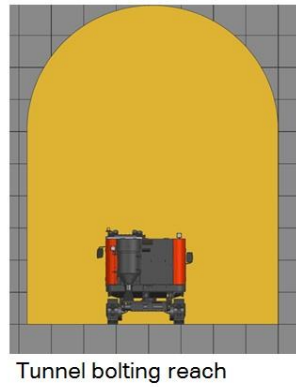
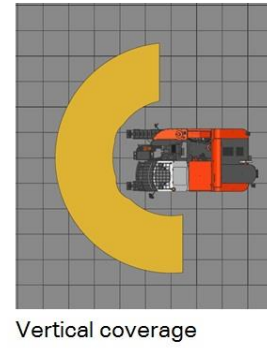
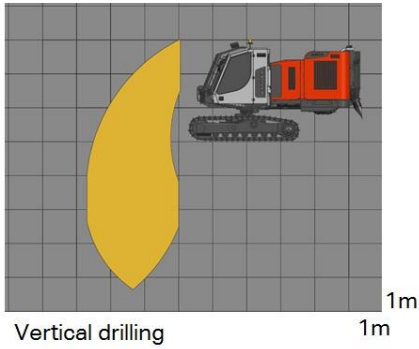

DIMENSIONS	
Weight	15 400 kg
Width	2.5 m
Height	a/b, 3.2 m/3.6 m
With safety cage	3.2 m/3.8 m
Total length	8.4 m / 11.3 m

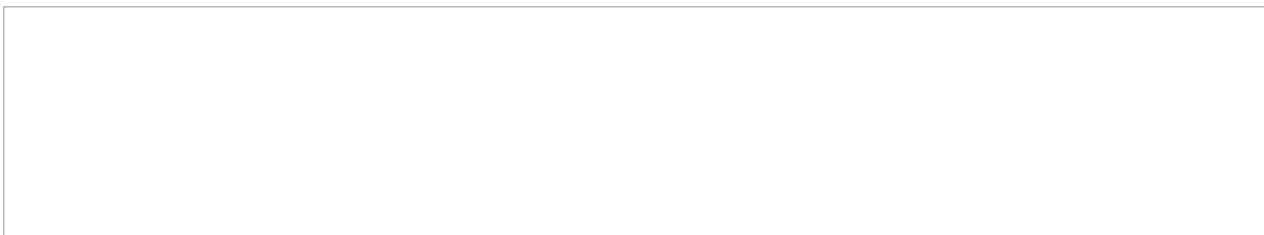

Sandvik Mining and Rock Technology reserves the right to make changes to the information on this data sheet without prior notification to users. Please contact a Sandvik representative for clarification on specifications and options.

ROCKTECHNOLOGY.SANDVIK