

HL710S HYDRAULIC ROCK DRILL

TECHNICAL SPECIFICATION

Sandvik HL710S is a hydraulic top hammer rock drill designed for DL2710 and DL2720 underground longhole drills. It is capable of drilling $\varnothing 54 \dots 89$ mm holes up to 38 meters in depth, using T35, T38, T45, T51 MF-rods or $\varnothing 65$ mm tube rods.

The HL710S hydraulic rock drill is designed to ensure high drilling capacity, easy maintenance and low operating cost. The construction of the rock drill is based on the main body modules tied together with four short side bolts; this ensures minimum number of joint faces and large contact surfaces. The percussion module is simple in design and consists of only two moving parts – the piston and the distributor sleeve around the piston. The moving parts are not in contact with the rock drill body modules.

There are two rotation motor variants to meet the rotation torque and RPM requirements of different hole diameters and rock formations. The optional power extractor is used for opening rock tool joints manually. The design of the HL710S is covered by several patents.

KEY FEATURES

Hole diameter range	54 - 89 mm
Kinetic power	20 kW
Percussion rate	52 Hz
Percussion pressure	Up to 190 bar
Rotation pressure	Up to 200 bar
Rotation motor range	OMT200 / 250
Stabilizer	Sleeve type
Shank length	600 mm

ROCK TOOLS AND HOLE DIAMETERS

Thread	Rod \varnothing (mm)	Hole \varnothing (mm)
T35	39	54 - 57
T38	39	64
T45	46	76
T45	65 (tube)	76 - 89
T51	52	89

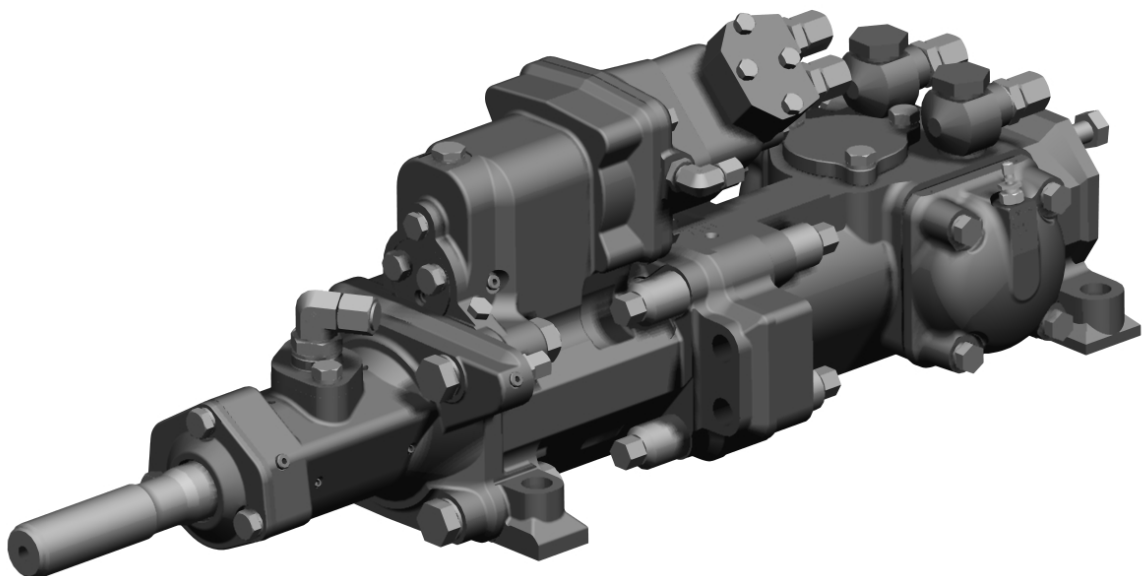

MAIN DIMENSIONS

Overall length (A)	1 340 mm
Length (B)	1 135 mm
Profile height (C)	286 mm
Width	332 mm
Weight	245 kg

ROTATION MECHANISM

Motor	Orbit type	
Motor type	OMT200	OMT250
Torque (200 bar)	1 095 Nm	1 335 Nm
Rotation speed	0 - 180 rpm	0 - 180 rpm
Flow (at max.speed)	79 l/min	99 l/min

FLUSHING PRESSURE

Max. pressure (air / water)	20 bar
-----------------------------	--------

ACCUMULATORS

Accumulator gas	Nitrogen N2
High pressure (HP)	50 bar
Low pressure (LP)	4 bar
Filling valve	Vg8 DIN7756

SHANK LUBRICATION

Air flow	200 - 300 l/min
Pressure	4 - 7 bar
Oil consumption	250 - 550 g/h

OIL RECOMMENDATION

Oil operating temperature	+40°C up to +60°C
---------------------------	-------------------

Oil recommendation	See Sandvik drill lubricant recommendation for detailed information
--------------------	---

OPTION

Special tools for HL710S Complete set	ID 150 730 78
Special tools for HL710S Field kit	ID 150 734 88
Power extractor	See separate specification

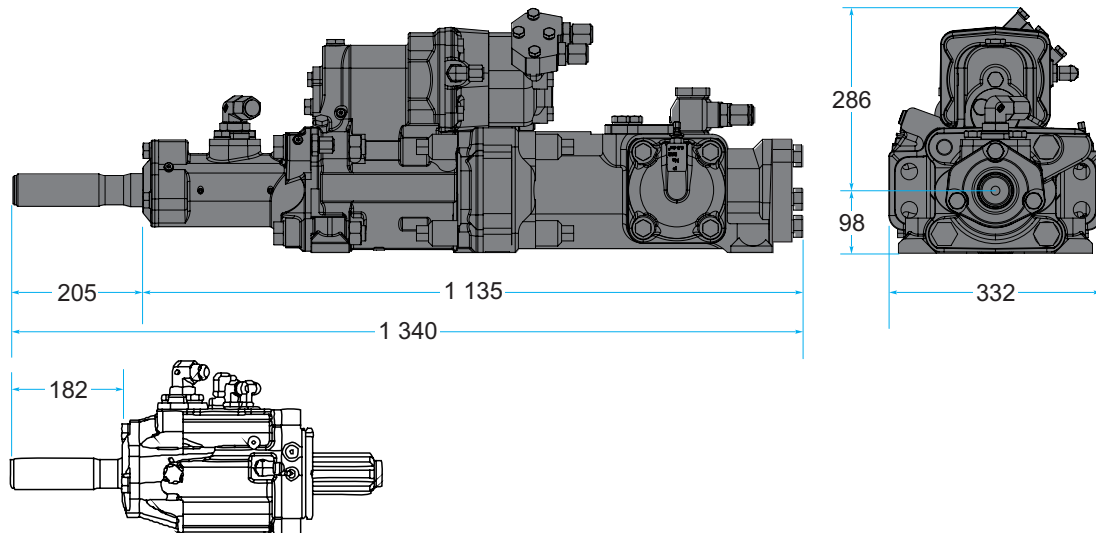

All dimensions in mm

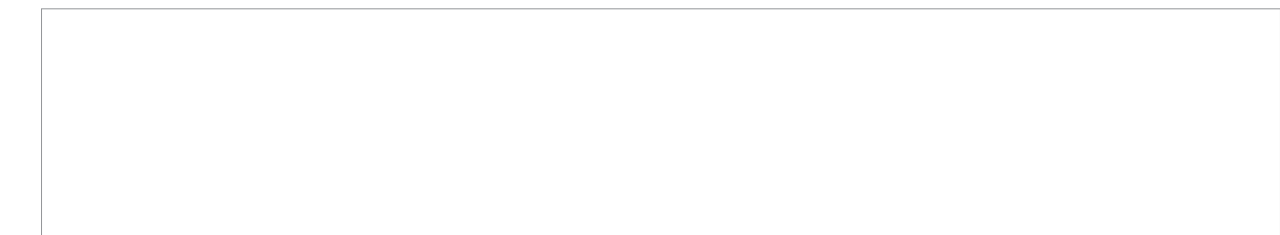

Sandvik Mining reserves the right to make changes to the information on this data sheet without prior notification to users. Please contact a Sandvik representative for clarification on specifications and options.