



SANDVIK TH315 UNDERGROUND TRUCK

TECHNICAL SPECIFICATION

Sandvik TH315 is a narrow 15 metric tonne truck with a 7.5 m² box, fitting in a 3 x 3 meter heading. The truck is built to offer the flexible mobility necessary in narrow-vein mining conditions. This mining truck carries high payloads for its weight and is maneuverable and quick on inclines.

The truck is equipped with an reliable and powerful Volvo Euro Stage III A / Tier 3 diesel engine, and it features an excellent power to weight ratio.

Sideways seating in Sandvik TH 315 operator's compartment offers comfort in applications which require both forward and reverse operation. The equipment has joystick steering and dump box control. Visibility from the operator's compartment has been improved e.g. with a perforated box front edge and optional reverse camera. Color-coded three-point of contact access system with fold-out ladders and handles offers easy access to the maintenance areas on top of the truck. Efficient and long-life LED lights improve visibility.

Sandvik Intelligent Control System with 7" LCD color display and inbuilt diagnostics helps to monitor equipment health, access log files and act timely on alarms.

Sandvik TH315 is well proven, designed to be reliable and easy to maintain, and especially well suited for:

- Ramp and drift development in small mines
- Small tunneling projects
- Two pass loading with Sandvik LH307 narrow vein loader



CAPACITIES

Payload capacity	15 000 kg
Standard dump box	7.5 m ³

SPEEDS FORWARD (LEVEL/LOADED)

1st gear	6.0 km/h
2nd gear	12.2 km/h
3rd gear	20.9 km/h
4th gear	35.9 km/h

DUMP BOX MOTION TIMES & MOVEMENTS

Discharging time	10 sec
Dumping angle	60°

OPERATING WEIGHTS *

Total operating weight	18 400 kg
Front axle	13 400 kg
Rear axle	5 000 kg

LOADED WEIGHTS *

Total loaded weight	33 400 kg
Front axle	15 300 kg
Rear axle	18 100 kg

* Unit weight is dependent on the selected options

OPERATIONAL CONDITIONS AND LIMITS

Environmental temperature	From -20°C to +50°C
	With engine Volvo TAD851VE
Standard operating altitude	from -1500 m to +3000 m at 25°C without rated power derate

REQUIREMENTS AND COMPLIANCE

Compliance with 2006/95/EC Low voltage directive
Design based on EN 1889-1. Machines for underground mines. Mobile machines working underground. Safety.
Part 1: Rubber tyred vehicles.
Electrical system based on IEC 60204-1. Safety of machinery – Electrical equipment of machines – Part 1: General requirements

POWER TRAIN

ENGINE

Diesel engine	Volvo TAD851VE (Tier 3)
Output	185 kw (252 hp) @ 2200 rpm
Torque	1150 Nm @ 1500 rpm
Number of cylinders	In-line 6
Displacement	7.7 l
Cooling system	Liquid cooled
Combustion principle	4-stroke, direct injection, turbo, after cooler
Air filtration	Dry type
Electric system	24 V
Emissions	Tier 3, Euro Stage III A
Ventilation rate (Ultra low sulphur diesel)	CANMET 12,100 CFM 5.71 m ³ /s, MSHA 9,000 CFM
Particulate index (Ultra low sulphur diesel)	MSHA Particulate Index 9000 CFM
Exhaust system	Catalytic converter with muffler
Average fuel consumption at 50% load	27 l/h
Fuel tank refill capacity	240 l

CONVERTER

Converter with lock-up integrated into transmission

TRANSMISSION

Manual transmission with electric remote shifting system. Four forward and four reverse gears.

Dana 14000 series

TIRES

Tire size (Tires are application approved. Brand and type subject to availability)

16.0 R 25 E4

AXLES

Front axle	Kessler D81 series spring applied hydraulic operated brakes, equipped with standard differential, oscillation
Rear axle	Kessler D81 series spring applied hydraulic operated brakes, equipped with standard differential

OPERATOR'S COMPARTMENT

CANOPY

ROPS certification according to EN ISO 3471
FOPS certification according to EN ISO 3449
No high pressure hoses in the operator's compartment
Inclinometers to indicate operating angle
Emergency exit
Floor washable with water to reduce dust
Three-point contact access system with replaceable and colour coded handles and steps
Remote circuit breaker switch

OPERATOR'S SEAT

Low frequency suspension
Height adjustment
Adjustment according to the operator's weight
Fore-aft isolation
Padded and adjustable arm rests
Adjustable lumbar support
Selectable damping
Two-point seat belt

CONTROL SYSTEM, DASHBOARD AND DISPLAYS

Sandvik Intelligent Control system	Displayed as text and with light (1-module system)
Critical warnings and alarms	Electrical gauges, 7" Display
Instrument Panel	Illuminated switches

FRAME

REAR AND FRONT FRAME

High strength structure with optimized material thicknesses. Reduced own weight for higher overall hauling capacity and long structural lifetime. Welded steel construction.	
Central hinge	Adjustable lower bearing
Tanks	Tanks are part of the frame structure
Automatic central lubrication	

HYDRAULICS

MAIN COMPONENTS

Door interlock for brakes and box hydraulics	
Oil cooler for hydraulic and transmission oil	Capability up to 50°C ambient temperature
Fittings	ORFS
Hydraulic oil tank capacity	182 l
Sight glass for oil level	2 pcs

STEERING HYDRAULICS

Full hydraulic power steering, center articulated with double acting steering cylinder.

Steering main valve	Pilot operated
Steering hydraulic cylinders	125 mm, 1 pc
Steering pump	Gear pump

DUMP BOX HYDRAULICS

Full hydraulic open-center system with one gear pump. Oil flows to the dump box hydraulic system from the pump when the steering system is not in use. Joystick dump box control.

Hydraulic pump	Gear pump
Control valve	Solenoid operated
Main valve	Solenoid operated
Cylinders	185 mm, 1 pc

BRAKES

Service brakes are spring applied; hydraulically operated multi disc wet brakes on all wheels. Two independent circuits: one for the front and one for the rear axle. Service brakes also function as an emergency and parking brake. Brake system performance complies with requirements of EN ISO 3450, AS2958.1 and SABS 1589

Neutral brake	
Automatic brake activation system, ABA	
Electrically driven emergency brake release pump	
Brake pedal valve	Foot operated pedal, fully modulated

ELECTRICAL EQUIPMENT

MAIN COMPONENTS

Reverse alarm (CE)	
Alternator	28 V, 110 A
Batteries	2 x 12V, 925 CCA
Starter	24 V, 5.5 kW
LED lights:	
Driving lights	4 pcs in front 2 pcs in rear
LED lights:	
Working lights	1 pc in front 1 pc in rear
Control system	Color display, inbuilt system diagnostics

INCLUDED SAFETY FEATURES

FIRE SAFETY

Portable fire extinguisher, 6 kg (CE)
Hot side - cold side design
Isolation of combustibles and ignition sources
Heat insulation on exhaust manifold, turbo, and isolated exhaust pipe

ENERGY ISOLATION

Lockable main switch, ground level access
Emergency stop push buttons according to EN ISO 13850
Pressure release in the radiator cap
Automatic discharge for pressure accumulators (brake system and pilot circuit)
Frame articulation locking device
Mechanical dump box locking device

DOCUMENTATION

STANDARD MANUALS

Operator's Manual	English and other EU languages
Maintenance Manual	English and other EU languages
Parts Manual	English
Service and Repair Manual	English
ToolMan	2 x USB stick in pdf format, includes all the manuals
Decals	English and other EU languages

OPTIONS

Flashing beacon
Reverse Camera
Spare rim 11.25-25/2.0 (for tyres 16.00R25)
Fire suppression system ANSUL, 1 tank, 6 nozzles (CEN), including auto shutdown

DIMENSIONS

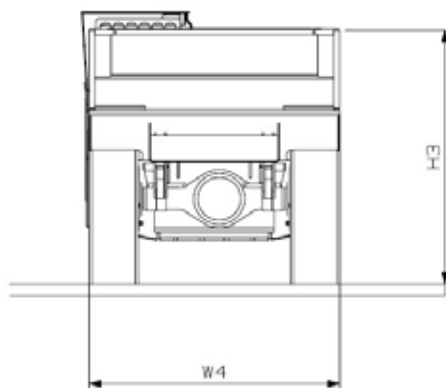
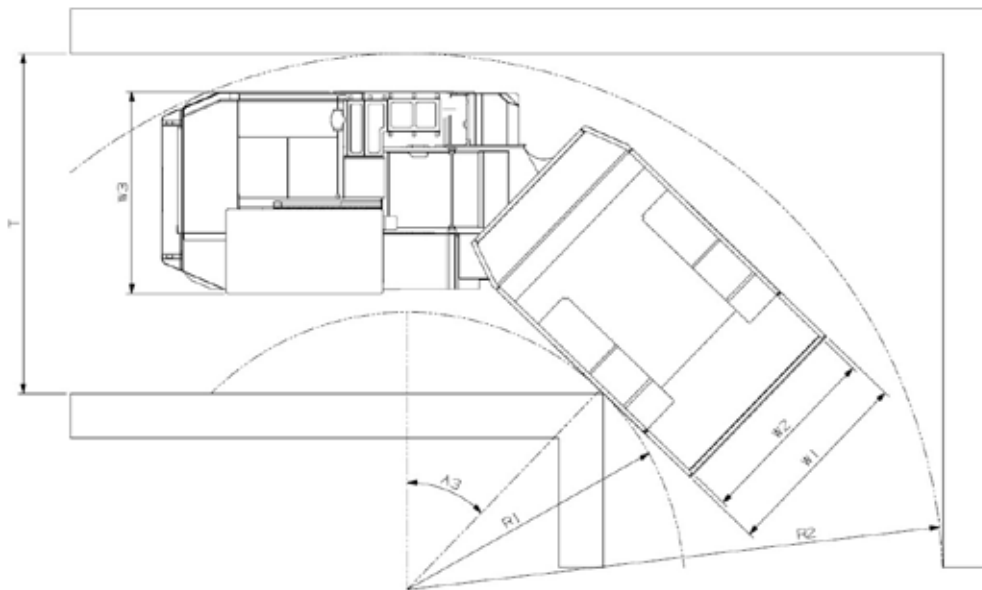
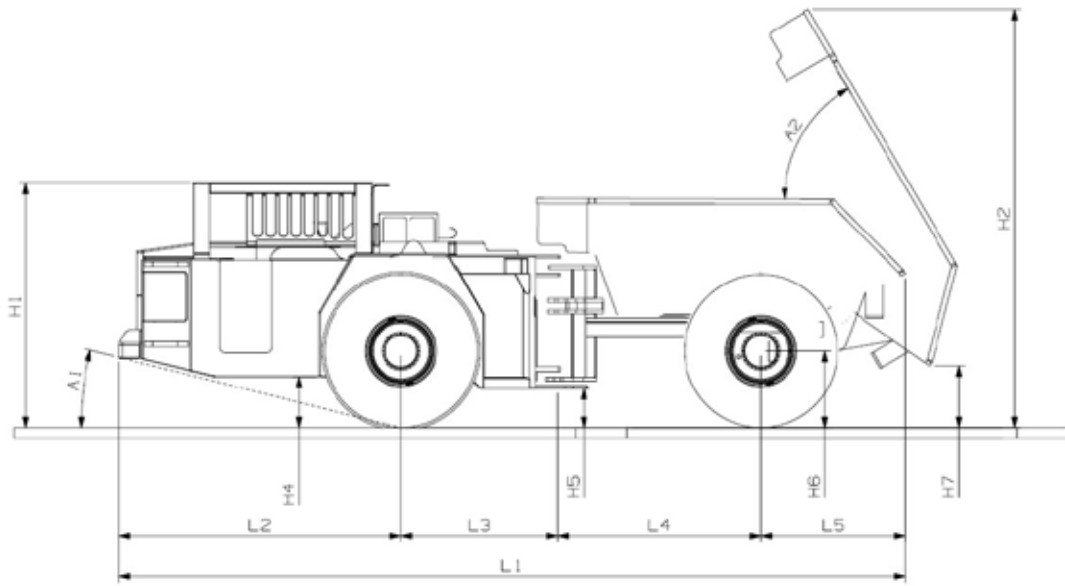

DIMENSIONS

	Standard
Dump box alternatives (m ³)	7.5 m ³
Material broken density (kg/m ³) (FF 0.9)	2200 kg/m ³
L1 (mm)	7710
L2 (mm)	2768
L3 (mm)	1422
L4 (mm)	2108
L5 (mm)	1412
H1 (mm)	2395
H2 (mm)	4096
H3 (mm)	2238
H4 (mm)	498
H5 (mm)	334
H6 (mm)	750
H7 (mm)	606
W1 (mm)	2207
W2 (mm)	2105
W3 (mm)	2274
W4 (mm)	2207
A1	14°
A2	60°
A3	44°
R1 (mm)	3126
R2 (mm)	6041
T (mm)	3830

GRADE PERFORMANCE

Volvo TAD851VE (Tier 3)

Calculated with 3% rolling resistance

With lock-up

EMPTY

Percent grade	0.0	10.0	14.3	20.0
Ratio		1:10	1:7	1:5
1st gear (km/h)	6.0	5.9	5.8	5.7
2nd gear (km/h)	12.4	11.8	11.5	10.8
3rd gear (km/h)	21.4	18.9	15.3	
4th gear (km/h)	37.2			

LOADED

Percent grade	0.0	10.0	14.3	20.0
Ratio		1:10	1:7	1:5
1st gear (km/h)	6.0	5.7	5.6	5.5
2nd gear (km/h)	12.2	10.5	8.4	
3rd gear (km/h)	20.9			
4th gear (km/h)	35.9			

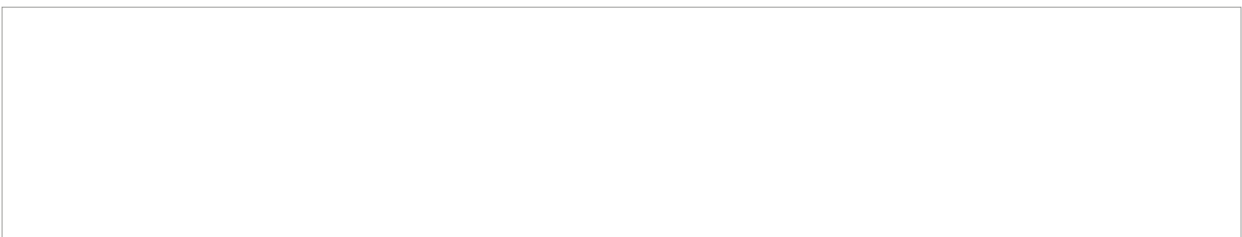

Sandvik Mining and Rock Technology reserves the right to make changes to the information on this data sheet without prior notification to users. Please contact a Sandvik representative for clarification on specifications and options.