



SANDVIK LH202 NARROW VEIN LOADER

TECHNICAL SPECIFICATION

The LH202 is a compact and lightweight loader for narrow vein mining with the best payload to own weight ratio in its class. The small-size loader offers reduced dilution, better flexibility and operator safety when working in narrow vein operations. The loader is easy to operate and maintain, and it features an operator's compartment that is located in the rear frame of the machine for increased operator safety.

The LH202 is full of features which help mines maximize tonnes and minimize extraction costs. It has been engineered to optimize machine width, length and turning radius, enabling operation in more narrow tunnels and for lower operational costs. The equipment is appreciated for its low fuel consumption, and it can be equipped with a Euro Stage IV / Tier 4 F low-emission engine from Deutz.

In addition to mining applications, the compact and agile equipment fits well for civil engineering and construction projects for building new and improving existing infrastructure. Due to its relatively light weight and the possibility to disassemble the equipment for transport, the LH202 is a fit match for small-dimensioned construction sites, even if located in remote areas within challenging access.

The LH202 loader is a fit pair with the development drill rig Sandvik DD210 and the long-hole jumbo Sandvik DL210.



CAPACITIES

Tramming capacity	3 000 kg
Break out force, lift	5 810 kg
Break out force, tilt	6 425 kg
Standard bucket	1.3 m ³

SPEED FORWARD & REVERSE (LEVEL/LOADED) WITH DEUTZ BF4L914 ENGINE

Tramming speed	10 km/h
----------------	---------

BUCKET MOTION TIMES

Raising time	4.8 sec
Lowering time	3.3 sec
Dumping time	5.5 sec

OPERATING WEIGHTS

Total operating weight	8 800 kg
Front axle	3 300 kg
Rear axle	5 500 kg

LOADED WEIGHTS

Total loaded weight	11 800 kg
Front axle	7 900 kg
Rear axle	3 900 kg

OPERATIONAL CONDITIONS AND LIMITS

Environmental temperature	From -20° C to +48° C
Standard operating altitude	Below 4500 m

REQUIREMENTS AND COMPLIANCE

Compliance with 2006/95/EC Low voltage directive

Compliance with 2004/108/EC Electromagnetic compatibility directive

Design based on EN 1889-1. Machines for underground mines. Mobile machines working underground. Safety. Part 1: Rubber tyred vehicles.

Electrical system based on IEC 60204-1. Safety of machinery – Electrical equipment of machines – Part 1: General requirements

POWER TRAIN

ENGINE

Diesel engine	Deutz BF4L914
Output	50 kW @ 2300 rpm
Torque	245 Nm @ 1600 rpm
Number of cylinders	In-line 4
Displacement	4.314 l
Cooling system	Air cooled
Combustion principle	4-stroke, turbo-charger
Air filtration	Two stage filtration, dry type
Electric system	24 V
Emissions	Tier 2, Euro Stage II
Exhaust system	Double wall exhaust pipe with catalytic purifier/muffler
Average fuel consumption at 50 % load	9.0 l / h
Fuel tank refill capacity	80 l

TRANSMISSION

Hydrostatic transmission with forward and reverse

AXLES

Front axle	Kessler D41, SAHR brakes, Limited slip differential
Rear axle	Kessler D41, SAHR brakes, No-slip differential, oscillating

TIRES

Tire size (Tires are application approved. Brand and type subject to availability.)	9.00 R20 L5S
---	--------------

FRAME

REAR AND FRONT FRAME

High strength welded steel structure with optimized material thicknesses

Central hinge with adjustable upper bearing

Tanks bolted to the frame

OPERATOR'S COMPARTMENT

CANOPY

ROPS certification according to EN ISO 3471

FOPS certification according to EN ISO 3449

No high pressure hoses in the operator's compartment

Inclinometers to indicate operating angle

Emergency exit

Floor washable with water to reduce dust

Three-point contact access system

12 V output for communication radio connection (Only available if equipped with Tier 4 engine)

Remote circuit breaker switch

OPERATOR'S SEAT

Low frequency suspension

Height adjustment

Adjustment according to the operator's weight

Fore-aft isolation

Padded and adjustable arm rests

Adjustable lumbar support

Two-point seat belt

DASHBOARD AND DISPLAYS

Critical warnings and alarms displayed as warning lights

Instrument panel with electric gauges and illuminated switches

HYDRAULICS

Door interlock for brakes and boom, bucket, and steering hydraulics

Oil cooler for hydraulic oil

ORFS fittings

ORFS hoses

Hydraulic oil tank capacity 120 l

Sight glass for oil level, 2 pcs

STEERING HYDRAULICS

Hydraulically operated, center-point articulation, power steering with one double acting cylinder. Steering controlled by hydraulic joystick. Interlock protection.

Steering main valve Open center type

Steering hydraulic cylinders 80 mm, 1 pc

Steering pump Gear type

Steering and servo hydraulic pumps Gear type

BUCKET HYDRAULICS

The oil flow from steering hydraulic pump is directed to bucket hydraulics when steering is not used. Joystick bucket and boom control (hydraulic), equipped with gear pump that delivers oil to the bucket hydraulic main valve.

Boom system Straight boom

Lift cylinders 100 mm, 2 pcs

Dump cylinder 125 mm, 1 pc

Main valve Open center type

Pump for bucket hydraulics Gear type

BRAKES

Service brakes are spring applied; hydraulically released multidisc wet brakes on all wheels. Two independent circuits: one for the front and one for the rear axle. Service brakes also function as an emergency and parking brake. Brake system performance complies with requirements of EN ISO 3450, AS2958.1 and SABS 1589.

Neutral brake

Automatic brake activation system, ABA

Emergency brake release pump (Electric, 2 kW)

ELECTRICAL EQUIPMENT

MAIN COMPONENTS

Alternator	55 A
Batteries	2 x 12V
Starter	4 kW, 24 V
Driving lights	LED lights: 2 pcs in front 2 pcs in rear 2 pcs in canopy
Parking, brake and indicator (blinkers) lights	LED lights: 2 pcs in front 2 pcs in rear
Reverse alarm	
Flashing beacon	

INCLUDED SAFETY FEATURES

FIRE SAFETY

Portable fire extinguisher, 6 kg

Hot side - cold side design

Isolation of combustibles and ignition sources

Heat insulation on exhaust manifold, turbo, and isolated exhaust pipe

ENERGY ISOLATION

Lockable main switch, ground level access

Emergency stop push buttons according to EN ISO 13850

Pressure release in the radiator cap (Standard in Tier 4 engine. Not available for Tier 2 engine.)

Automatic discharge for pressure accumulators (brake system and pilot circuit)

Frame articulation locking device

Mechanical boom locking device

Wheel chocks and brackets

GRADE PERFORMANCE

Deutz BF4L914

Empty

Percent grade	0	2.0	4.0	6.0	8.0	10.0	12.5	14.3	17
Speed (km/h)	10	10	10	10	10	10	8.8	7.9	7.0

Loaded

Percent grade	0	2.0	4.0	6.0	8.0	10.0	12.5	14.3	17
Speed (km/h)	10	10	10	10	9.3	7.9	6.8	6	5.3

DOCUMENTATION

STANDARD MANUALS

Operator's Manual	English and other EU languages
Maintenance Manual	English and other EU languages
Parts Manual	English
Service and Repair Manual	English
ToolMan	2 x USB stick in PDF format, includes all the manuals
Decals	English, French, Spanish, German

OPTIONS

Lower canopy (2017 mm)
Spare rim 10.00-25/1.5 (for tyres 14.00 R25)
Boom floating
Line of sight radio remote control HBC, analogue
Radio remote control interface HBC, analogue
Recovery kit (brake release by radio signal), hook included
Driving direction lights (red / green)
Electric filling pump for hydraulic oil
Wiggins fuel fill system
Arctic package (230V heater elements) for Tier4f engine only
Automatic central lubrication
ANSUL fire suppression system ANSUL, including auto shutdown
ANSUL fire suppression system ANSUL, with CHECKFIRE, including auto shutdown
Emergency steering

OPTIONAL ENGINES

Engine Deutz F4L914 air cooled, natural aspirated, 56 kW, 2300 rpm, Tier 2

Engine Deutz TD3.6 L4 liquid cooled, Turbo Charged, 55 kW, 2300 rpm, Tier 4 Final

DIMENSIONS

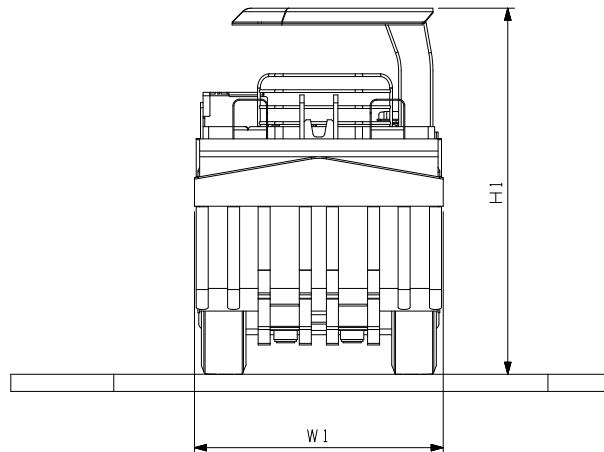
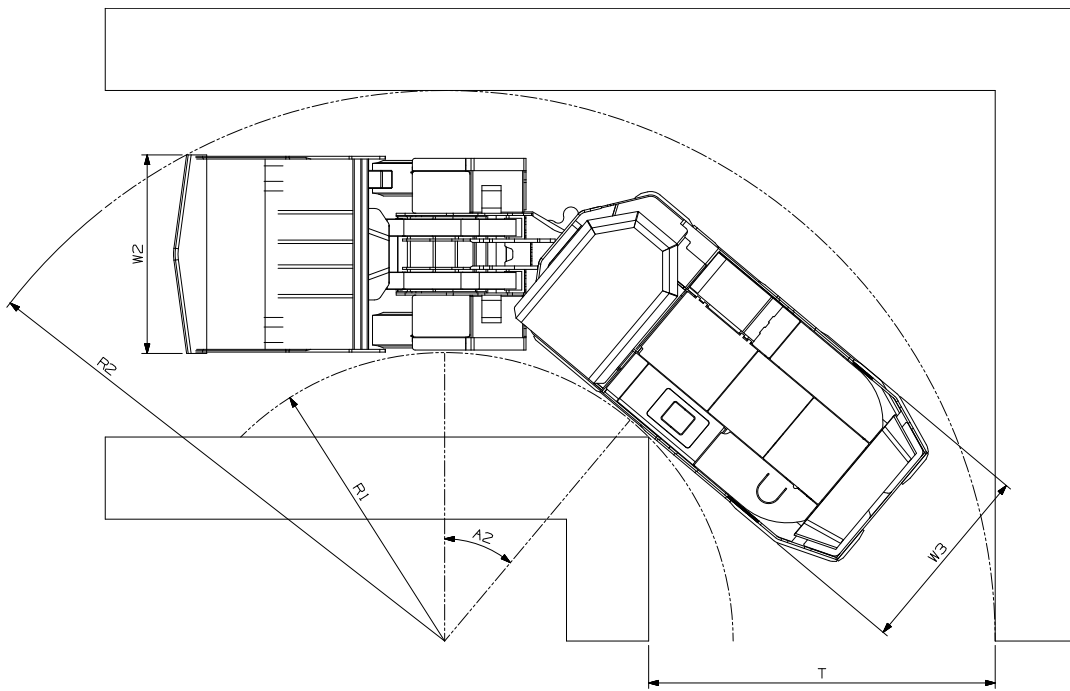
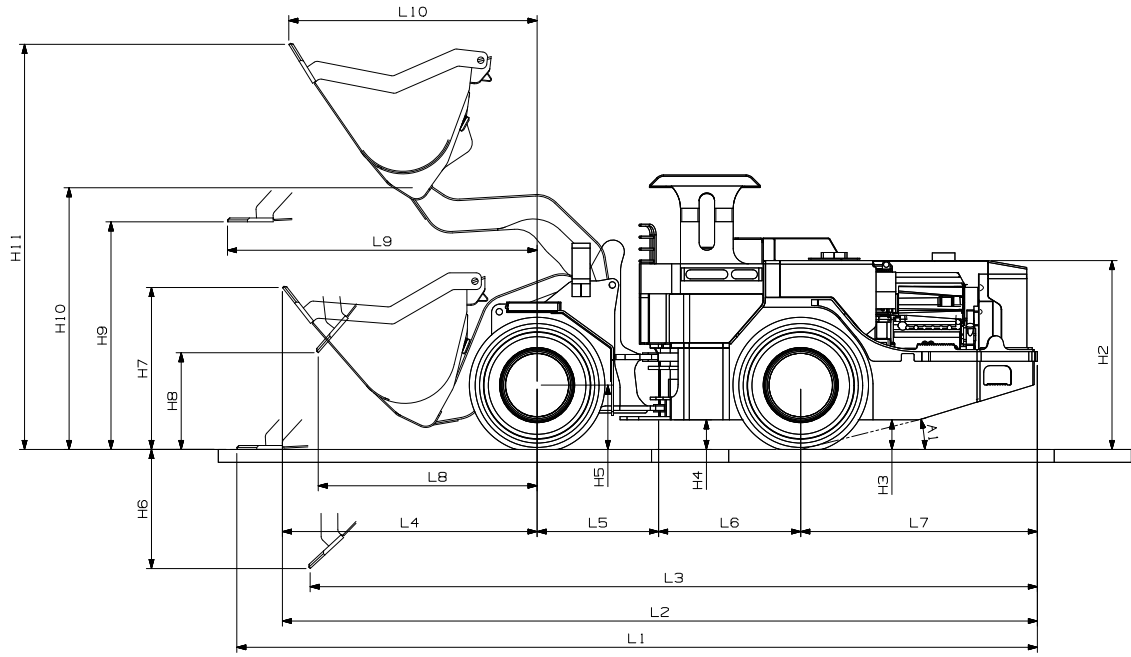

DIMENSIONS

	Standard		
Bucket alternatives (m ³)	1.3 m ³	1.5 m ³	1.75 m ³
Lip plate type	Bare lip	Bare lip	Bare lip
L1 (mm)	6220	6358	6312
L2 (mm)	5864	5774	5910
L3 (mm)	5649	5760	5736
L4 (mm)	1980	2054	2020
L5 (mm)	1000	1000	1000
L6 (mm)	1050	1050	1050
L7 (mm)	1840	1840	1840
L8 (mm)	1702	1804	1784
L9 (mm)	2407	2540	2500
L10 (mm)	1931	1999	1967
H1 (mm), open cabin, STD	2134	2134	2134
H1 (mm), open cabin, Low	2017	2017	2017
H2 (mm)	1468	1468	1468
H3 (mm)	230	230	230
H4 (mm)	188	188	188
H5 (mm)	500	500	500
H6 (mm)	926	1022	986
H7 (mm)	1259	1373	1347
H8 (mm)	752	653	691
H9 (mm)	1770	1772	1784
H10 (mm)	2035	2035	2035
H11 (mm)	3150	3273	3236
W1 (mm)	1450	1450	1666
W2 (mm)	1450	1450	1666
W3 (mm)	1400	1400	1400
A1	14°	14°	14°
A2	40.0°	40.0°	40.0°
R1, left turn (mm)	2107	2107	2107
R2, left turn (mm)	4021	4054	4182
T, left turn (mm)	2531	2564	2733
R1, right turn (mm)	2107	2107	2027
R2, right turn (mm)	4021	4054	4182
T, right turn (mm)	2531	2564	2733

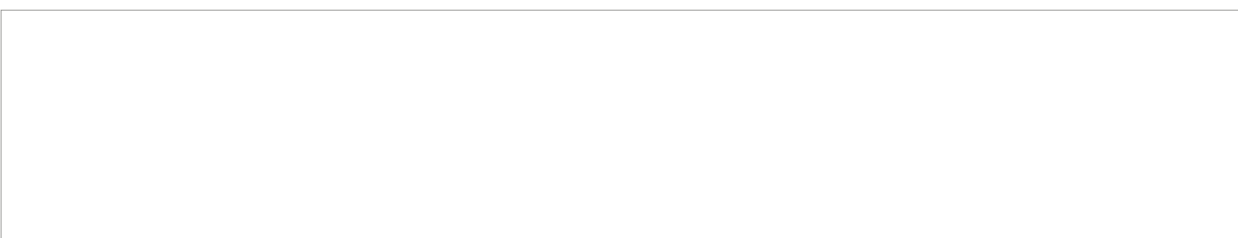

Sandvik Mining and Rock Technology reserves the right to make changes to the information on this data sheet without prior notification to users. Please contact a Sandvik representative for clarification on specifications and options.