



# DD2710 DEVELOPMENT DRILL

## TECHNICAL SPECIFICATION

Sandvik DD2710 is a compact and flexible single-boom electro-hydraulic jumbo for development drilling in narrow vein and mass mining as well as in tunneling, in cross sections up to 34 m<sup>2</sup>.

Sandvik DD2710 is equipped with Sandvik HLX5 hydraulic rock drill, which delivers 20 kW of percussion power for high penetration rates and good rock tool service life in varying rock conditions. The universal B26F boom is fitted with 360° feed rotation, automatic parallelism and a large and optimally shaped coverage, for fast and accurate face drilling and versatility. The direct controlled IBC control system has added automatic functions that allow the operator to concentrate safely on fast and accurate drilling.

Sandvik DD2710 is mounted on a 4-wheel drive frame-steered and diesel powered carrier, which features a FOPS-approved safety canopy, and layout designed for good visibility and stability in tramming in small mining drifts and tunnels. The operating and maintenance interface are designed for easy access, safe operation and all service points are accessible from ground level.

### KEY FEATURES

Coverage area	34 m <sup>2</sup>
Hydraulic rock drill	1 x HLX5 (20 kW)
Drill feed	1 x TF500-12' (12' rods)
Boom	1 x B26F
Hole length	3 440 mm (12' rods)
T-section width in turning	2 750 mm (TF512)
Transport width	1 600 mm
Transport height	2 070 mm / 2 750 mm
Transport length	10 065 mm (TF512)
Operating weight	11 600 kg depending on option



Scan or click to see the video.

## HYDRAULIC ROCK DRILL

Type of rock drill	HLX5 (TS2-232)
Percussion power	20 kW
Percussion pressure	Max. 220 bar
Percussion rate	67 Hz
Rotation speed	Max. 250 rpm (with OMS 80)
Rotation torque	400 Nm (with OMS 80)
Hole diameter (face drilling)	43 - 64 mm
Hole diameter (reaming)	76 - 127 mm
Recommended rod	T38 - Hex 35 - R32 T38 - Hex 35 - Alpha 330 T38 - Hex 35 - R35
Shank adapter (male)	T38
Weight	210 kg
Length	955 mm
Profile height	87 mm

## DRILLING FEED

Type		TF500-10'	TF500-12'	TF500-14'	TFX6/12
Feed force	kN	Max. 25	Max. 25	Max. 25	Max. 25 kN
Total length	mm	4 660	5 270	5 880	3 540 / 5370
Rod length	mm	3 090 (10')	3 700 (12')	4 305 (14')	1 830 (6') / 3 700 (12')
Hole length	mm	2 830	3 440	4 050	1 610 / 3 440
Weight (with-out hoses)	kg	470	500	530	620

## BOOM

Type of boom	B26F (TS2-259)
Face drilling coverage	29 m <sup>2</sup> (parallel holes)
Parallelism	Automatic hydraulic
Boom extension	1 200 mm
Feed extension	1 600 mm
Boom weight (without hoses)	1 850 kg
Feed roll-over	360°

## HYDRAULIC SYSTEM

Powerpack	HPP 555 (55 kW)
Operating principle	Direct hydraulic control
Percussion, rotation, feed and boom pump	65 cc + 35 cc + 33 cc (Triple pump)
Filtration (pressure / return)	10 μ / 10 μ
Oil tank volume	200 liters
Filling pump for hydraulic oil	Electric
Cooler for hydraulic oil	OW30 oil-to-water (30 kW)
Low oil level indication	Level indicator and automatic switch-off

## DRILLING CONTROL SYSTEM

Type of control system	IBCQF, hydraulic
Adjustable parameters	Full percussion and collaring Feed and rotation Flushing
Automatic features	Automatic stop drilling Anti-jamming

## ELECTRIC SYSTEM

Standard voltages	380 - 690 V (± 10%)
Frequency	50 - 60 Hz
Total installed power	70 kW
Main switch gear	NSX160N/38
IP classification	Specification TS2-132
Starting method	Star delta starter 380 - 575 V
Automatic cable reel	CR with tramming interlock
Cable reel control	At the operator station
Phase inverter detector	Automatic
Front lights (combined working and driving)	4 x 48 W LED (24 V)
Rear tramming lights	2 x 48 W LED (24 V)
Operator station light	1 x 5 W (24V)
Amber flashing light	LED (24 V)
Batteries	2 x 12 V, 80Ah

## AIR AND WATER SYSTEM

Flushing of holes	By water
Water booster pump type	WBP1 (3 kW)
Water pump capacity	33 l/min at 15 bar (inlet pressure = 4 bar)
Water pump inlet pressure	2 - 5.4 bar
Flushing water pressure	10 - 15 bar
Shank lubrication device	SLU-1 (air / oil mist)
Air compressor	CTN10 (1.0 m <sup>3</sup> /min, 7 bar)
Rock drill oil consumption	180 - 250 g/h
Rock drill air consumption	250 - 350 l/min

## OPERATOR'S SAFETY CANOPY

Canopy certification	FOPS (ISO 3449)
Unit height in tramming (FOPS)	High position : 2 750 mm Low position : 2 535 mm
Sound pressure level EN 791	Operator station: 102 dB(A) Emitted: 124 dB(A)
Operator's seat	For working / tramming Adjustable with seat belt

**CARRIER**

Type of carrier	MERCURY (frame steered)
Carrier articulation	± 35°
Rear axle oscillation	± 6°
Ground clearance	295 mm
Diesel engine	Deutz TCD3.6 L4 (74 kW, Tier 3, China III)
Exhaust catalyzer	Standard
Transmission	Hydrostatic, automotive
Wheel motors	4 x radial piston
Tires	10.00 - 15
Service brakes	Hydrostatic and positive braking
Parking and emergency brakes	SAHR fail safe type wet disc brakes
Tramming speed	8 km/h (Horizontal) 4 km/h (14%=1:7=8°)
Gradeability / sideways tilt	Max. 15° / 5°
Fuel tank	60 liters
Carrier stabilization	2 x Telescopic (front) 2 x Vertical (rear)
Brake release	Manual hand pump
Centralized greasing points	Carrier
Hand held fire extinguisher	1 x 6 kg (type ABC)
Tramming alarm	Standard
Colour scheme	Sandvik
Documentation	2 x Operator's manual 2 x Maintenance manual 2 x Technical manual (in English only) 2 x Parts manual (in English only) 2 x CD of manuals (PDF files)

**OPTIONAL FEATURES AND PACKAGES****Drilling feed**

*Feed length	TF510 (10' rods) or TF514 (14' rods)
*Telescopic feed	TFX6/12
Rod retainer	TRR1 incl. safety wire, add 35 mm length of the feed

**Cleaning system**

LP system with reel	Up to 15 bar (TS2-343)
HP system with reel	Up to 180 bar (TS2-343)

**Drilling control system**

Drilling and boom movement inhibition	2 x switches
---------------------------------------	--------------

**Electric system**

*Multi-voltage	550 - 1 000 V (50 / 60 Hz)
*Electric cables	Specification TS2-121
*Starting method	DOL for voltage above 575 V
Ground fault and overcurrent protection	VYK
Boom switch inhibition	2 x switches
Battery jump start	Optional

**Air and water system**

*Air mist flushing	With External water / internal air CTN16 with 1 x 60L air receiver
*End-of-hole flushing	With 1 x 60L air receiver
Air mine connection	IP5 air cleaner
*Dry drilling	CTN16 with 1 x 60L air receiver, air / oil cooler, dust hood on feed, readiness for hydraulic supply onboard dust collector
Hooks for water / air hose	2 hooks

**Greasing system**

Manual system	Greasing unit with pump, reel and nozzle (Spec. 5-2110)
---------------	---

**Operator's safety canopy**

Operator protection	Safety grill
---------------------	--------------

**Fire suppression system**

Manual system	Ansul, 6 nozzles (Spec. 5-9800)
---------------	---------------------------------

**Carrier**

*Foam filled tires	4 pcs
Wheel chocks and holders	2 Sets

**Extra items**

Berg plug and socket	
Spare rock drill	HLX5
Spare wheel assembly	Standard or foam filled tires
Special tools for rock drill	Complete set (Spec. 2-1861) Field kit (Spec. 2-1862)
Documentation	Extra manuals
Package: Country specific options	SAS (cluster lights, reflective taps and wheel chocks and holders)
*Package: Harsh water	Advanced (TS2-049)

\*) replaces standard feature

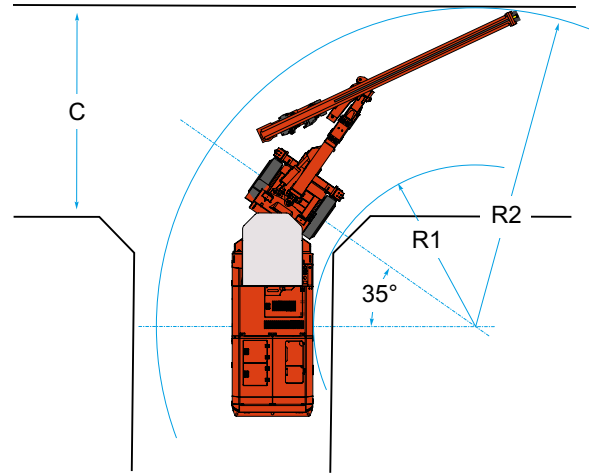
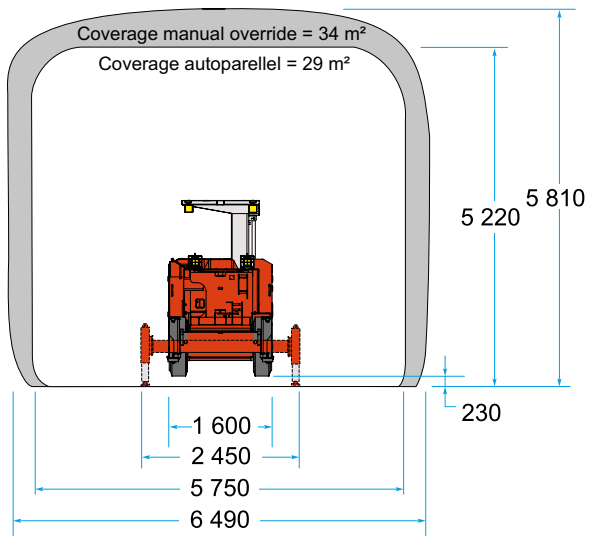

All dimensions in mm

Feed	R1	R2	C	L
TF500-10	2 900 mm	4 980 mm	2 630 mm	9 485 mm
TF500-12	2 900 mm	5 100 mm	2 750 mm	10 065 mm
TF500-14	2 900 mm	5 235 mm	2 880 mm	10 285 mm
TFX6/12	2 900 mm	4 930 mm	2 510 mm	9 810 mm

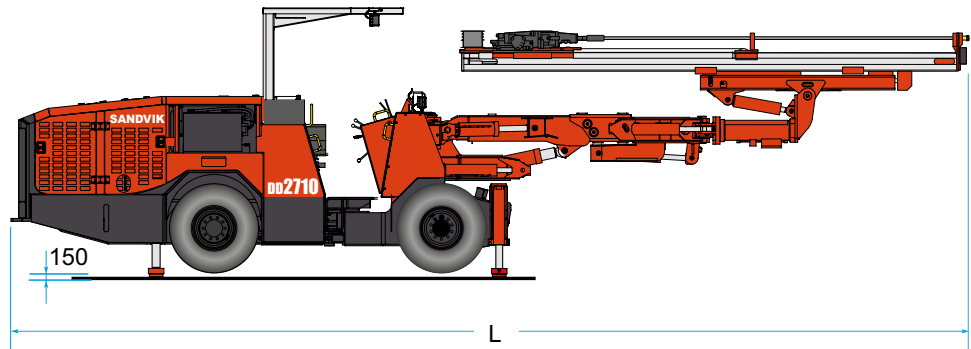
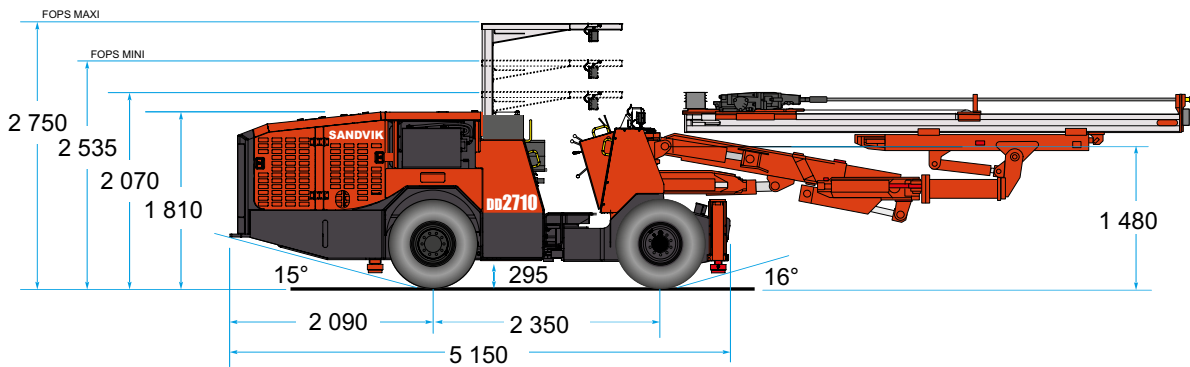

All dimensions in mm

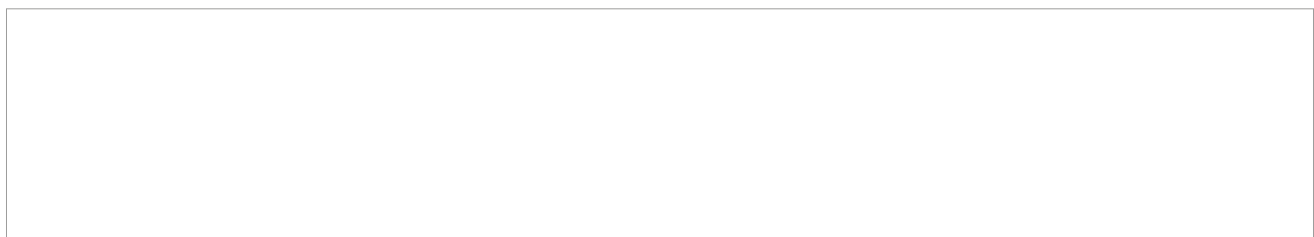

Sandvik Mining and Rock Technology reserves the right to make changes to the information on this data sheet without prior notification to users. Please contact a Sandvik representative for clarification on specifications and options.

ROCKTECHNOLOGY.SANDVIK

#### 4. SANDVIK DD2710 - DEVELOPMENT DRILL