



# QS331 CONE CRUSHER ENGINEERING IN MOTION



### TECHNICAL SPECIFICATIONS

KEY SPECIFICATIONS	DATA
Crusher type	Sandvik CS430
Speed	346 rpm to 366 rpm
Feed opening	up to 360 mm / 14 1/8"
CSS range	19 mm - 51 mm / 3/4" - 2"
Drive	PT Tech 12" Wet Clutch with PTO
Drive belts	8 SPC Single Belts

KEY SPECIFICATIONS	DATA
Power pack	
Engine type	Stage 3A / Tier 3 Cat C9 Acert or Stage 3B / Tier 4i Cat C9.3 Acert Stage 4 / Tier 4 Final CAT 9.3 Acert
Engine power	261 kW / 350 hp
Diesel tank size	660 litres / 174 USG
Hydraulic tank size	660 litres / 174 USG

Note. All weights and dimensions are for standard units only

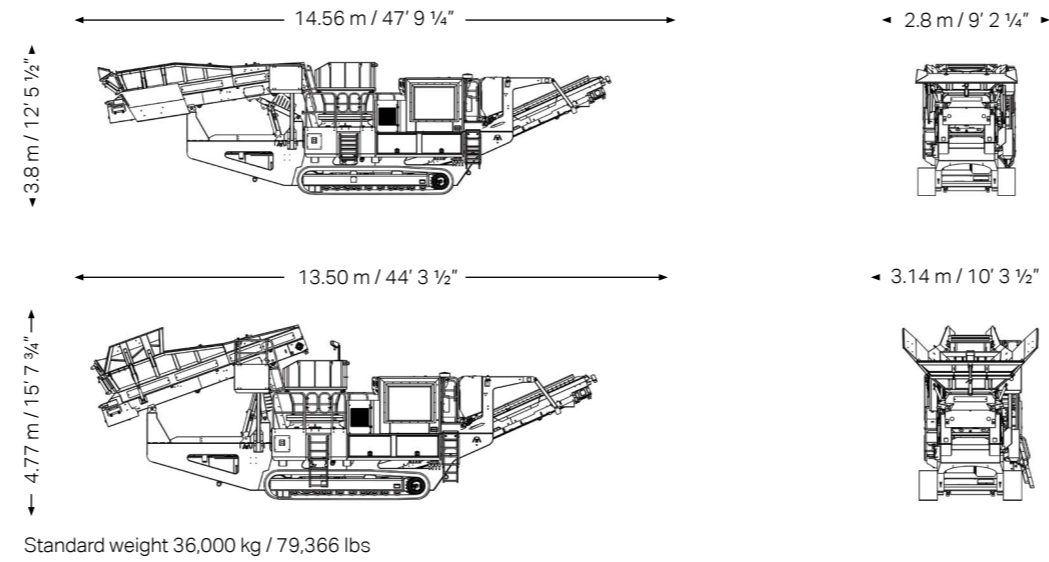

Capable of working in a primary or secondary application. Featuring the proven, high performing Sandvik CS430 Hydrocone.

- ⑤ - CLP Liners are designed to keep maximum feed size into the cone throughout the wear life of the liners. All liner options fit in one top shell
- Constant liner opening results in constant production performance throughout liner life
- ⑥ - Longer crushing chamber due to top & bottom support resulting in massive reductions in the chamber
- ⑦ - Bush arrangement has multiple settings to suit the required application
- Eccentric throw can be changed by simply turning the bush

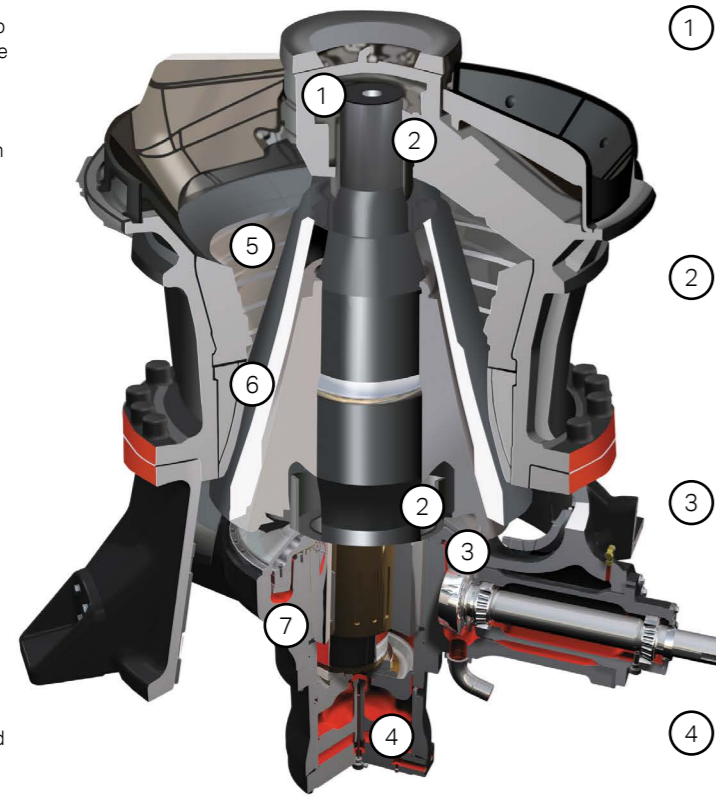

- ① - Unique crusher design eliminates the need for anti-spin device on head
- ② - Main Shaft is supported from both the Top and Bottom giving additional strength
- ③ - Helical drive gear arrangement for maximum durability and smooth, quiet operation
- ④ - Single piston design for gap setting and over load protection. CSS can also be adjusted whilst crushing





# QS331 CONE CRUSHER ENGINEERING IN MOTION

KEY SPECIFICATIONS	DATA
Equipment	Sandvik CS430 Gyratory cone
Maximum feed size	360 mm / 14 1/8"
Engine	C9 / C9.3 Acert 261 kW / 350 hp
Transport dimensions	14.56 m / 47' 9 1/4" (l) 2.80 m / 9' 2 1/4" (w) 3.8 m / 12' 5 1/2" (h)
Weight	36,000 kg / 79,366 lbs

## UNRIVALLED FLEXIBILITY

The QS331 is a high quality secondary cone crusher designed for the operator seeking a compact, fully mobile and robust plant. Featuring the world-proven CS430 cone crusher, it is capable of handling a feed size up to 90% larger than standard cones. It is able to produce large reduction ratios with minimal fines production and is ideally suited for crusher run, ballast, drainage stone or material for a tertiary crushing plant.

The QS331 is available with a choice of three concaves and different bush settings offering customers unrivalled flexibility and with a wide range of options, it can be tailored to suit many different applications worldwide.

## STANDARD FEATURES INCLUDE:

- Emissions compliant 261 kW / 350 hp engine for powerful cost efficient performance
- Camera overseeing the crushing chamber allows the operator full visibility of the feed material entering the crushing chamber
- Equipped with a hydroset CSS regulation system that provides overload protection, optimizes production and keeps track of liner wear
- Level sensor fitted above the crushing chamber regulates the feed to maximize production and reduction

**1 Main conveyor**

- 1000 mm / 39 1/2" wide main conveyor with a discharge height of 3065 mm / 10' 3/4"
- Dust suppression spray bars and canvas covers fitted as standard

**11 Hanging screen system (optional)**

- 4 x 1.5 m / 13' x 5' single deck screen for recirculation back to feed conveyor, or stockpiling through 90° rotation of oversize conveyor to produce two products
- Hydraulic operation from recirculating to stockpiling position
- Extended conveyor fitted as standard with HS option

**10 Cooling fan**

- Hydraulically driven cooling fan with auto reverse to back flush dust from radiator

**2 Power pack**

- 261 kW / 350 hp emissions compliant engine
- Direct drive for optimum efficiency and power transfer
- Easy access for service and maintenance
- Ground level drainage points
- Large capacity diesel tank 660 litres / 174 USG

**3 Cone**

- Fitted with the proven CS430 Sandvik cone for strength and reliability
- Equipped with Hydroset CSS regulation system for optimum production & protection
- Pressurised cone prevents dust ingress into the cone internals
- Various bush settings available to optimize product gradation and capacity
- Variable crusher speed via the engine to manipulate product gradation

**4 Feeder**

- Automated variable speed feed conveyor to ensure maximum production and reduction
- Bridge Coil (up and over) metal detector fitted to the feed conveyor providing optimum stability and controlled detection

**5 Hopper**

- Reinforced hydraulically folding hopper
- Wear resistant liner plates (optional)
- Hydraulic folding hopper extensions for increased hopper capacity and rear loading (optional)

**9 Control system**

- Highly efficient hydraulic and electric system provide ultimate system control
- A full colour PLC screen with a simple operator interface combined with a level sensor above the crushing chamber and load control system allows for a fully automated crushing process

**8 Steel pipework**

- Provides a safe and maintenance-free sealing solution, combined with better heat dissipation

**7 Tracks**

- 500 mm / 19 3/4" wide tracks driven by proportional umbilical control
- Radio remote (optional)

**6 Chassis**

- Heavy duty fabricated chassis on a tracked frame

## STANDARD FEATURES

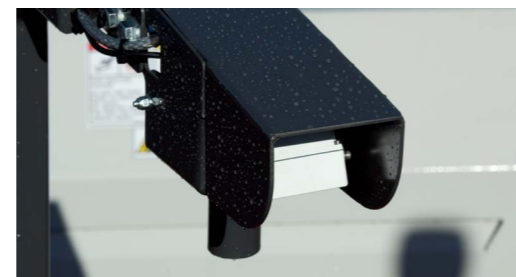

Camera and level sensor to ensure continuous feed



Bridge coil metal detector for controlled detection



Direct drive for maximum fuel efficiency



Easy access to the engine compartment



User friendly PLC control system with colour screen



C chamber with extremely large feed opening